

Dust Clouds around Peculiar SN impostors

ORyou Ohsawa

I.Sakon, T. Onaka, M. Tanaka, T. Moriya, T. Nozawa, K. Maeda,
K. Nomoto, N. Tominaga, F. Usui, H. Matsuhara, & H. Murakami

Grain Formation Workshop 2010

Contents

- NGC 300 Optical Transient
(NGC300OT)
- SN 2008S in NGC 6946

ダスト形成の疑いがある
変な天体を紹介

supernova impostor?



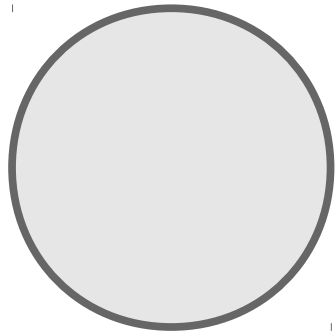

supernovae

$$\sim 10^{51} \text{ erg/s}$$

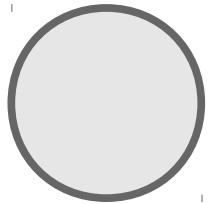

ILOTs (supernova impostors)

$$\sim 10^{49} \text{ erg/s}$$

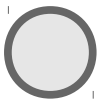

classical novae

$$\sim 10^{47} \text{ erg/s}$$

why peculiar?



complex spectra

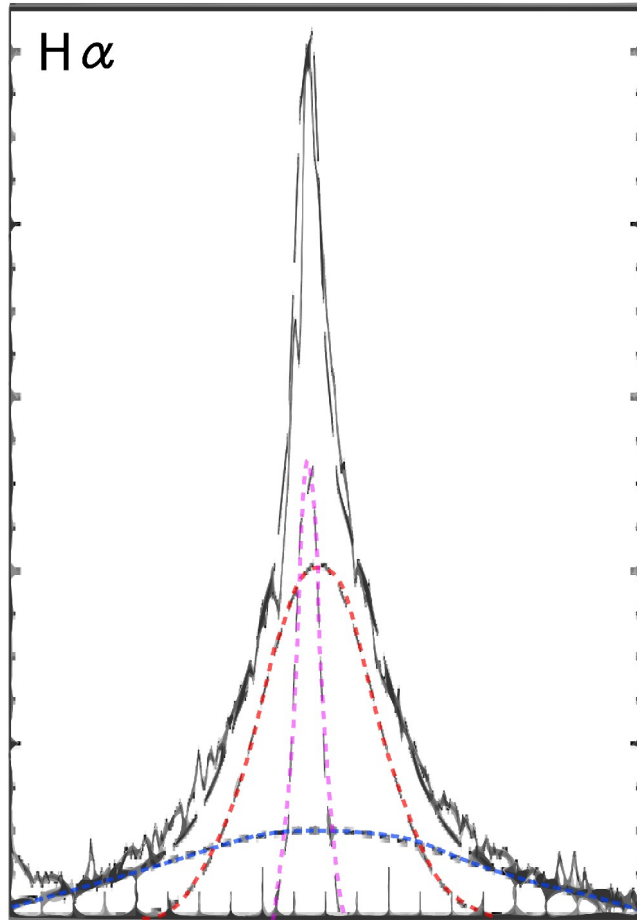

SN 2008S (Botticella+, 2009)

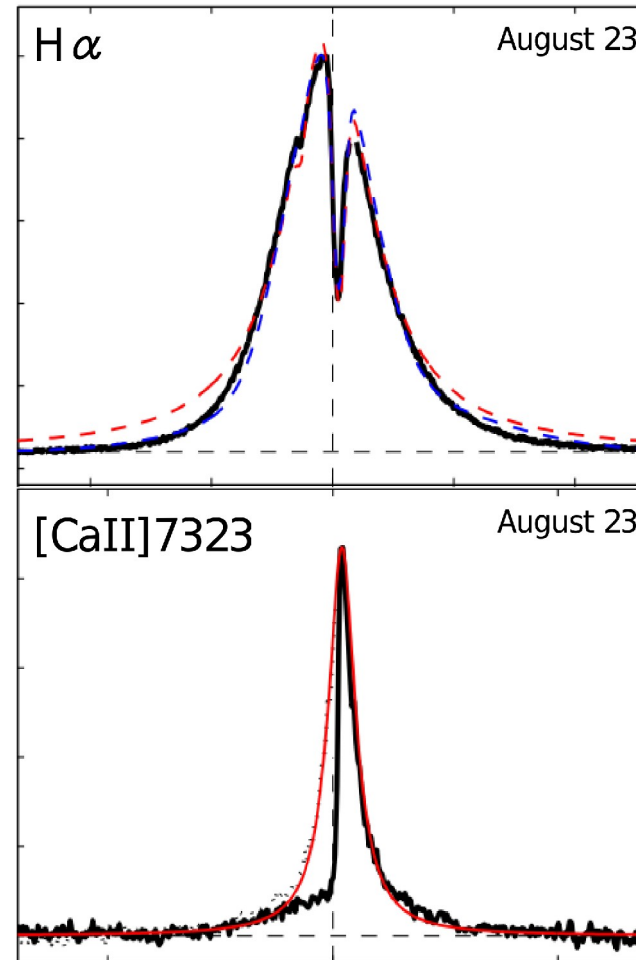

NGC3000T (Berger+, 2009)

dusty progenitor

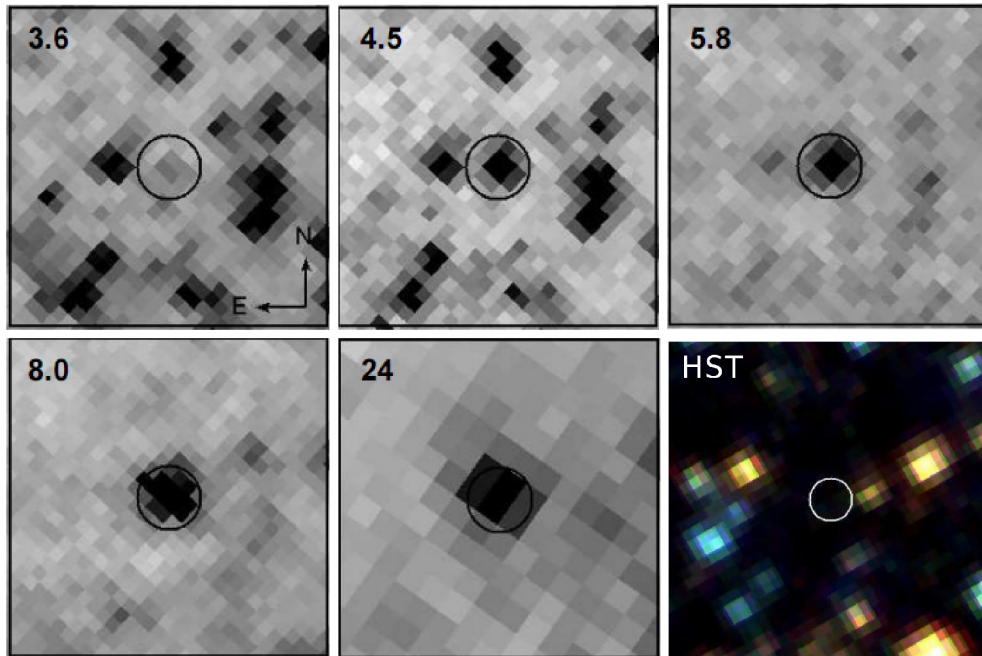

NGC300OT (Berger+, 2009)

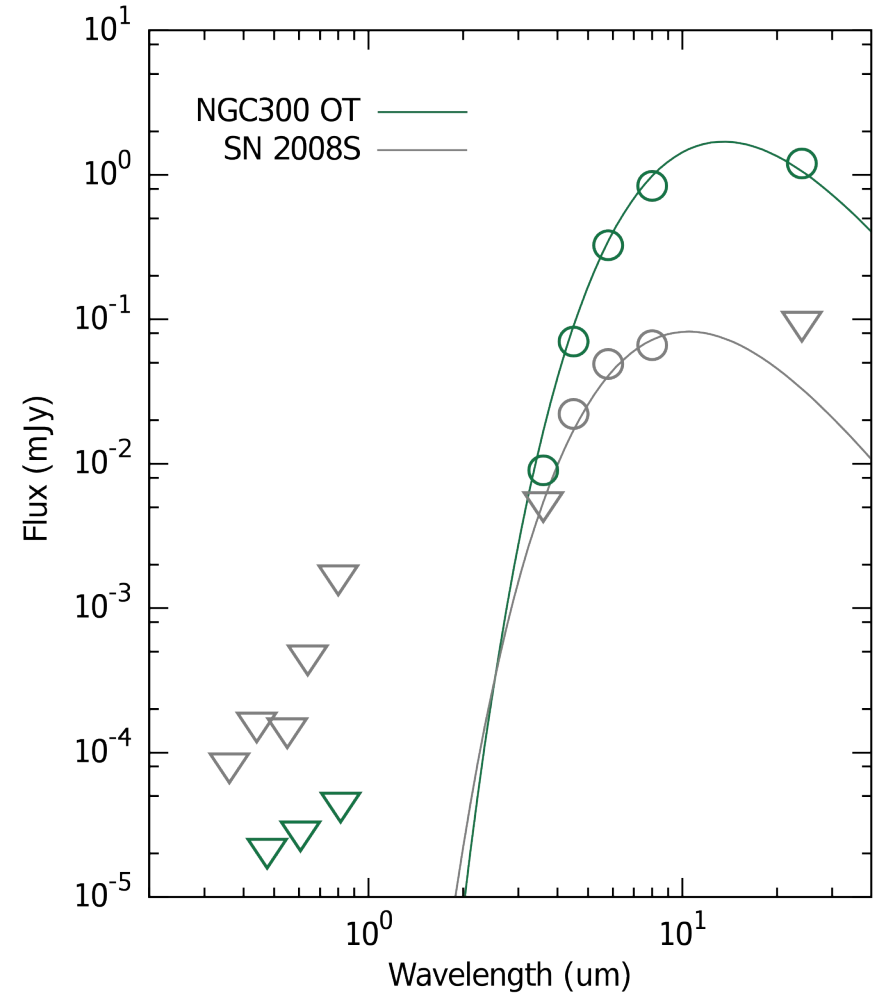

sign of dust formation

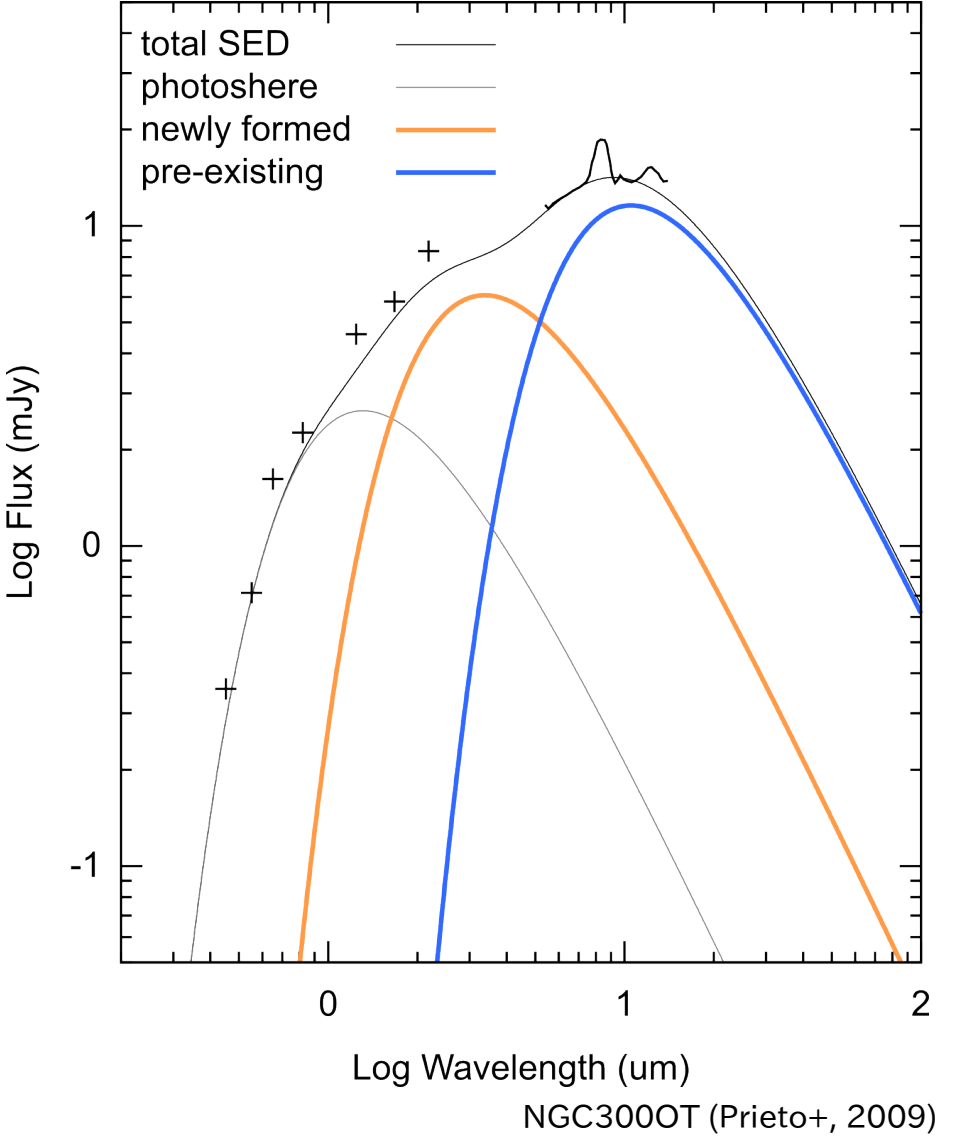
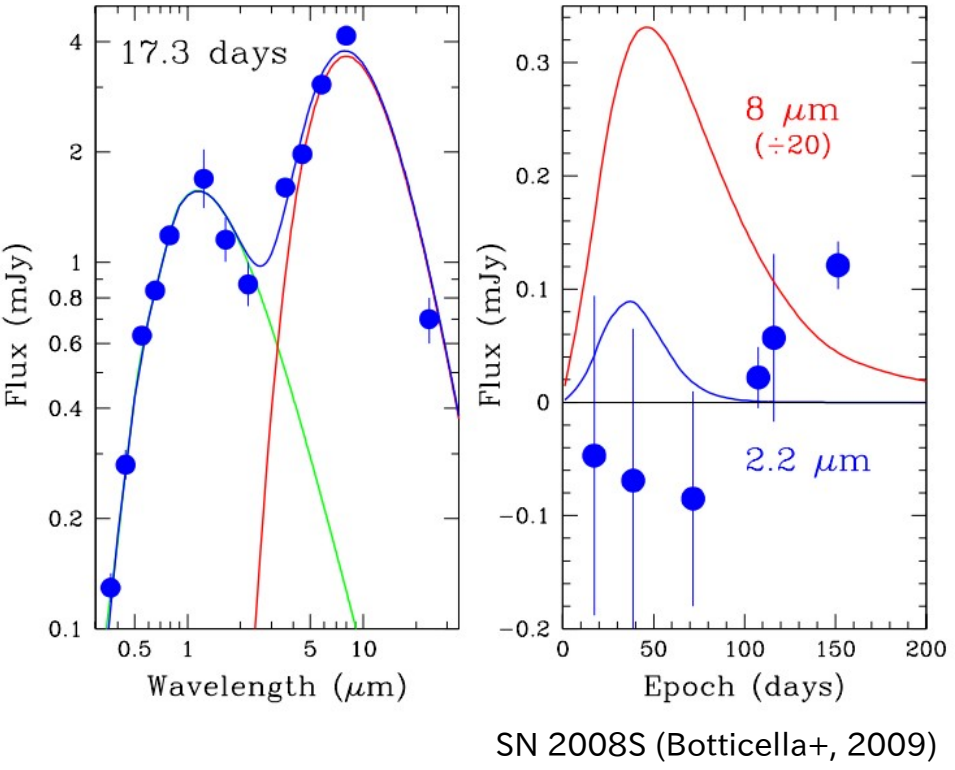

Overview

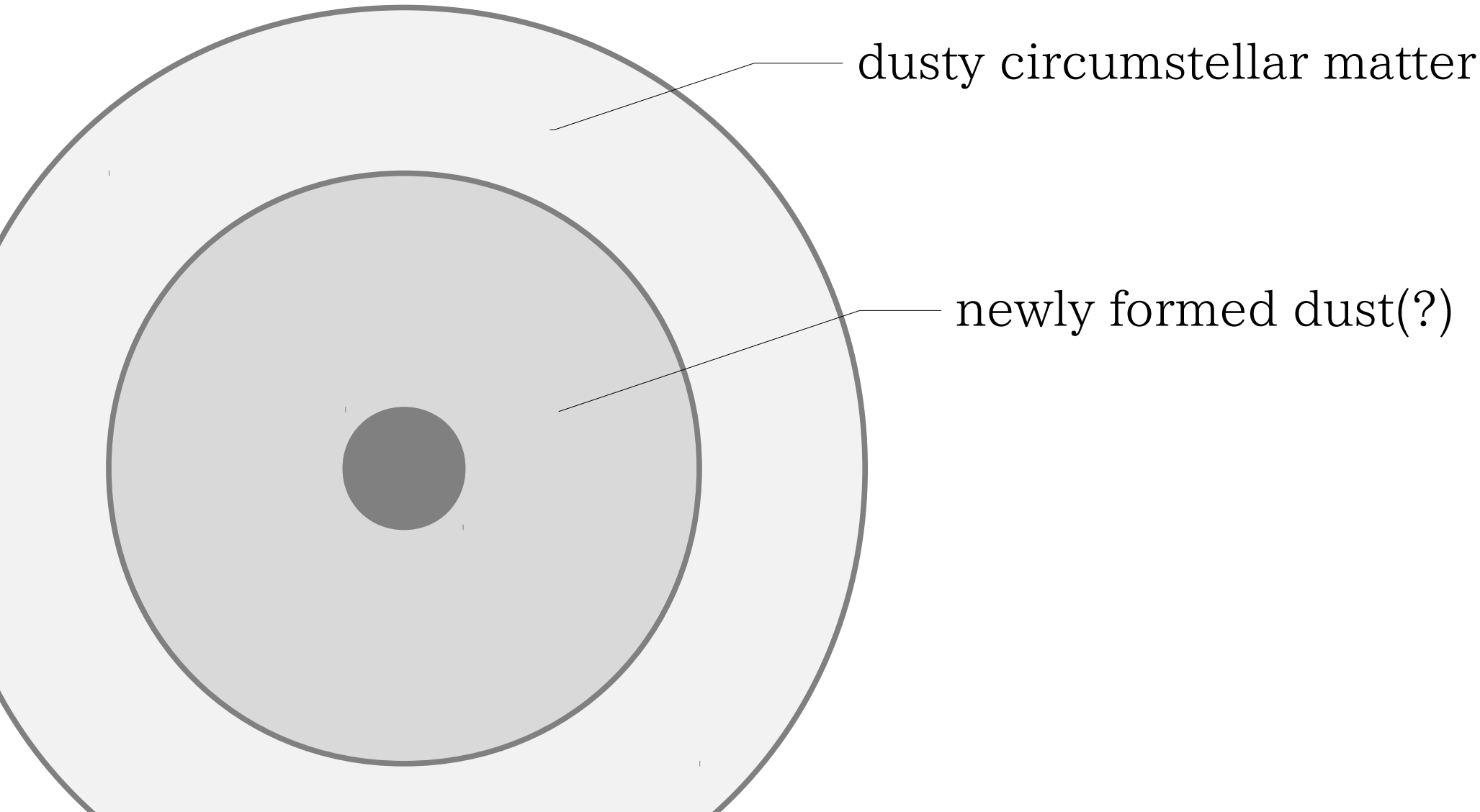

AKARI NIR observation

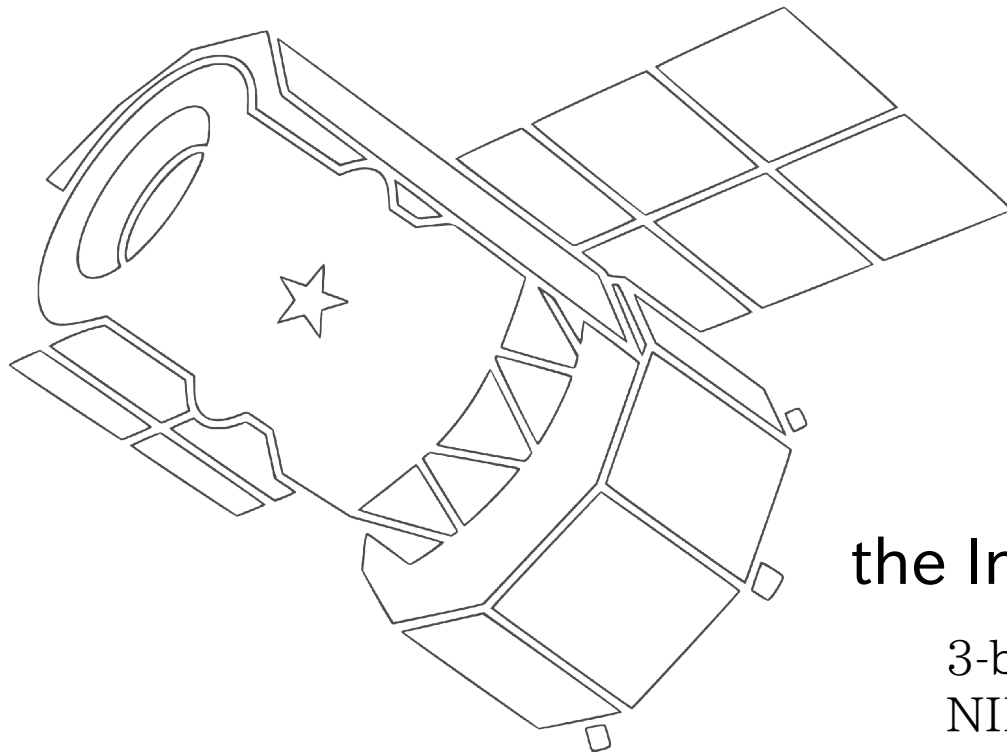

the Infrared Camera (IRC)

3-band 2.4(N2), 3.2(N3), 4.1(N4) imaging
NIR 2.5-5.0 μm spectroscopy

Director's Time での観測と Mission Program ISMGN (PI: H. Kaneda)
Open Time Program NEWSY (PI: I. Sakon) のアーカイブデータを使用

NGC 300 Optical Transient

discovered
on May 15, 2008
(~20 days after explosion)

distance:
~ 1.88Mpc
luminosity:
~ -12 mag.

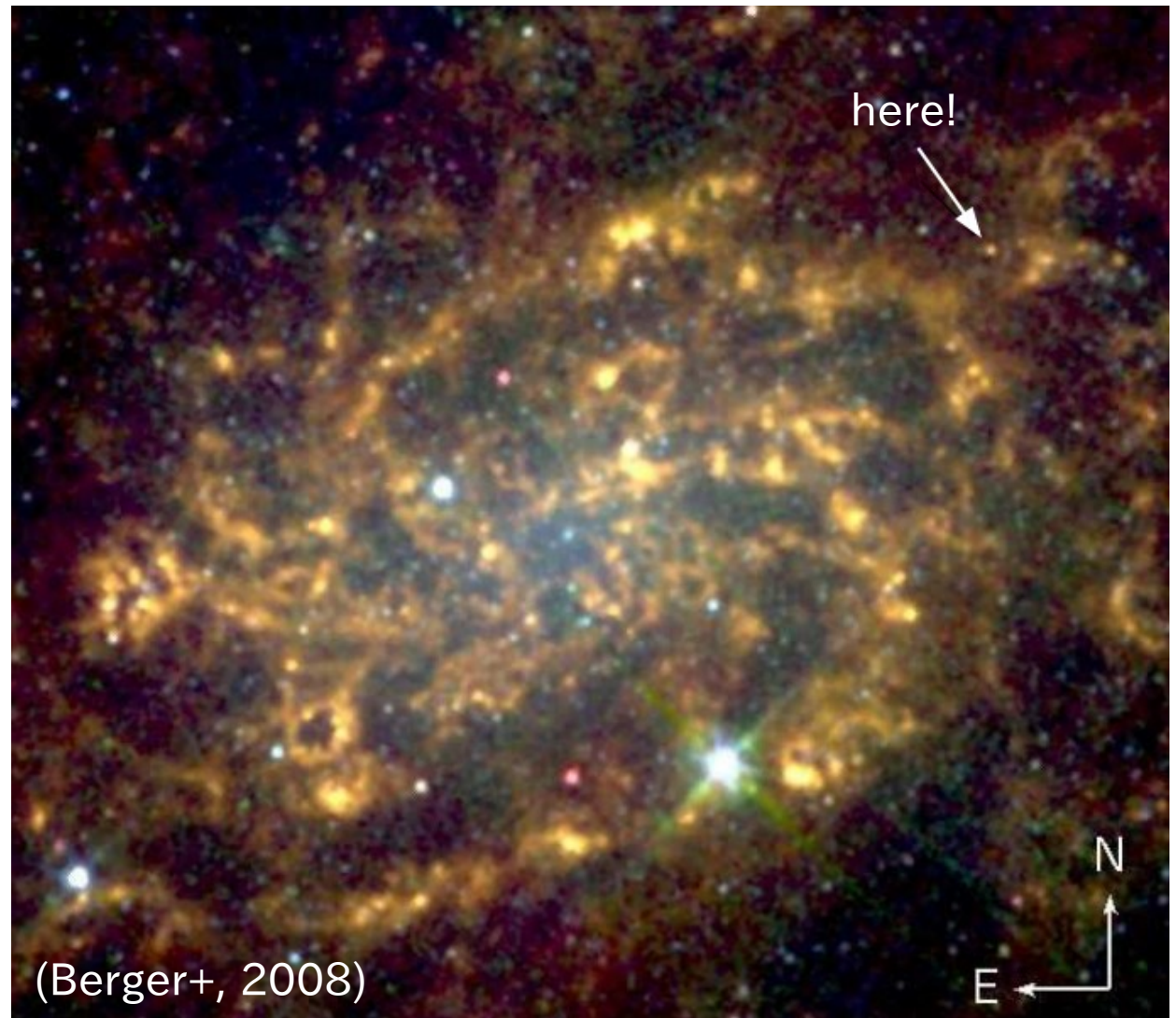

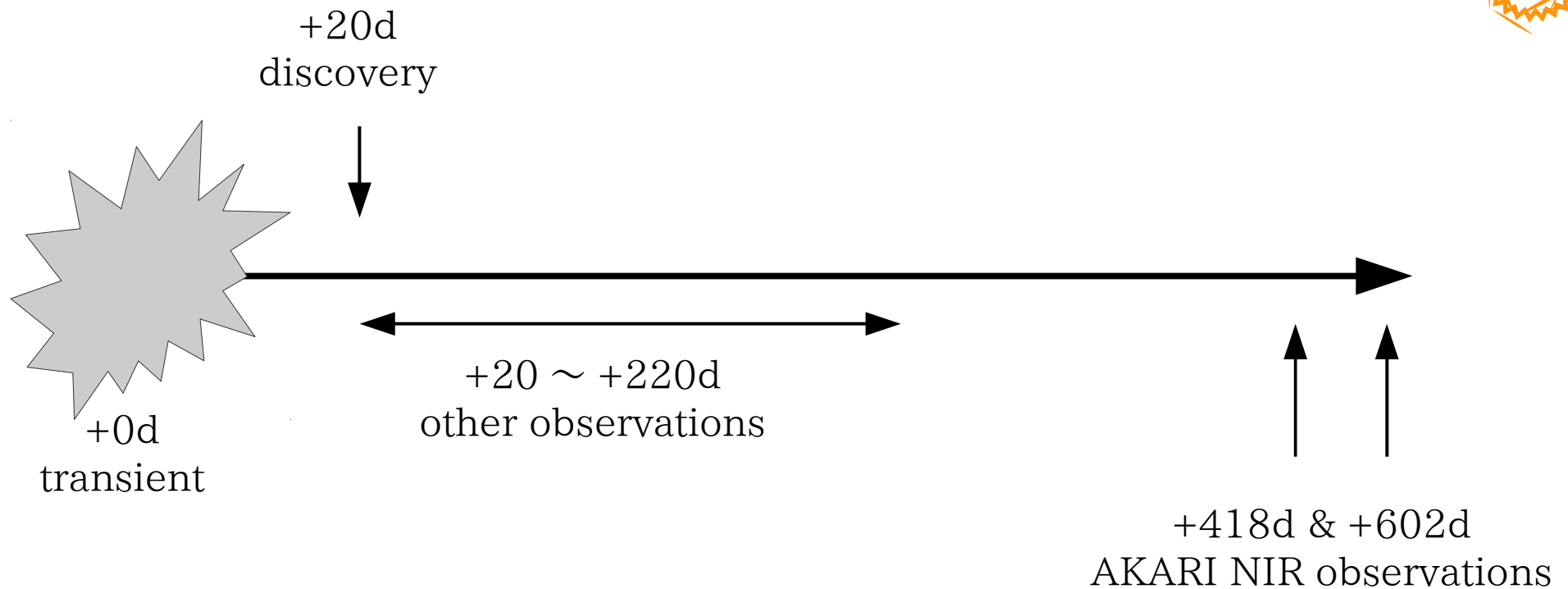

唯一の後期観測 (当時)

爆発から 418 日後と 602 日後の 2 epoch 観測
両 epoch とも 3 band の imaging と近赤外スペクトルを取得

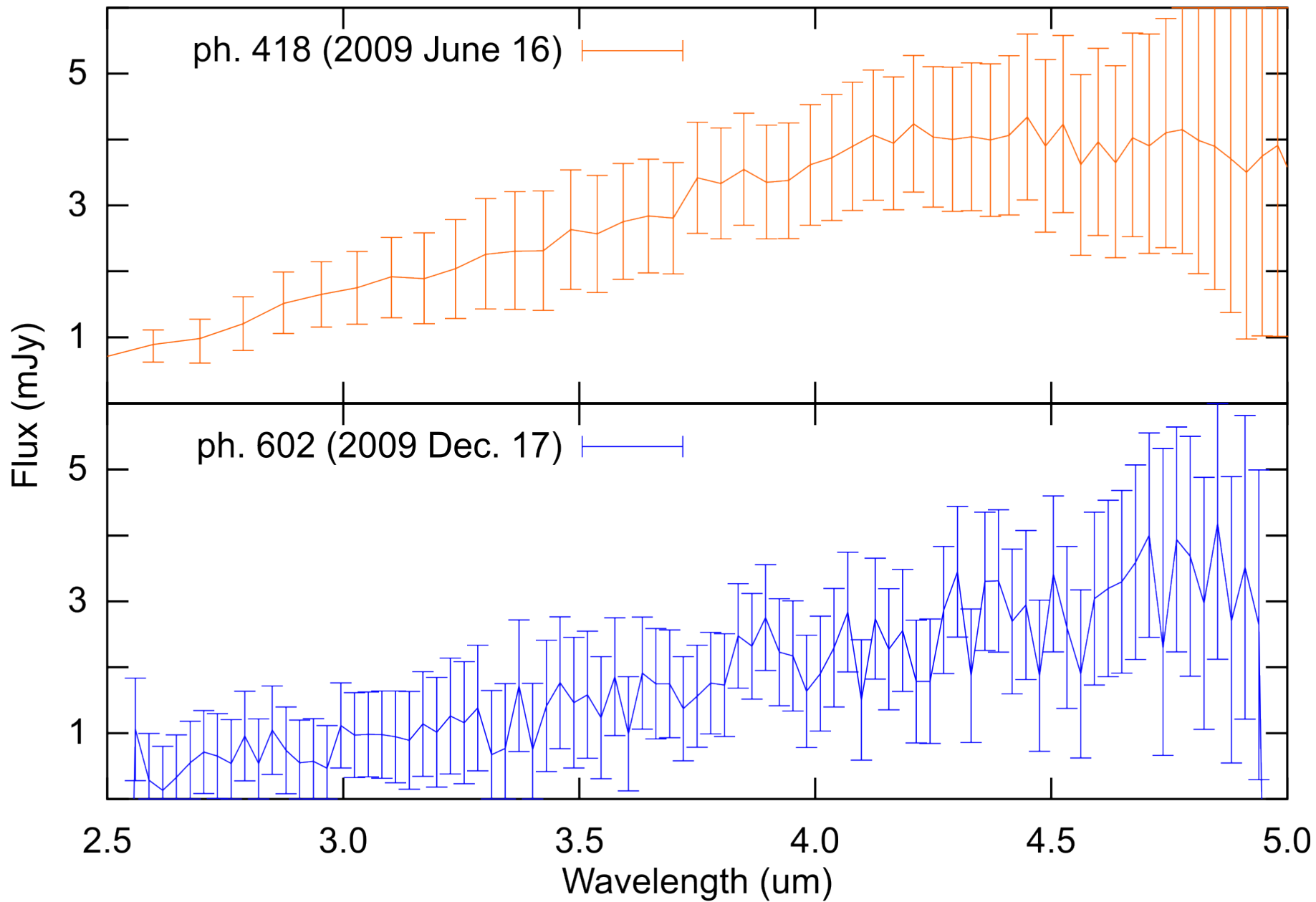

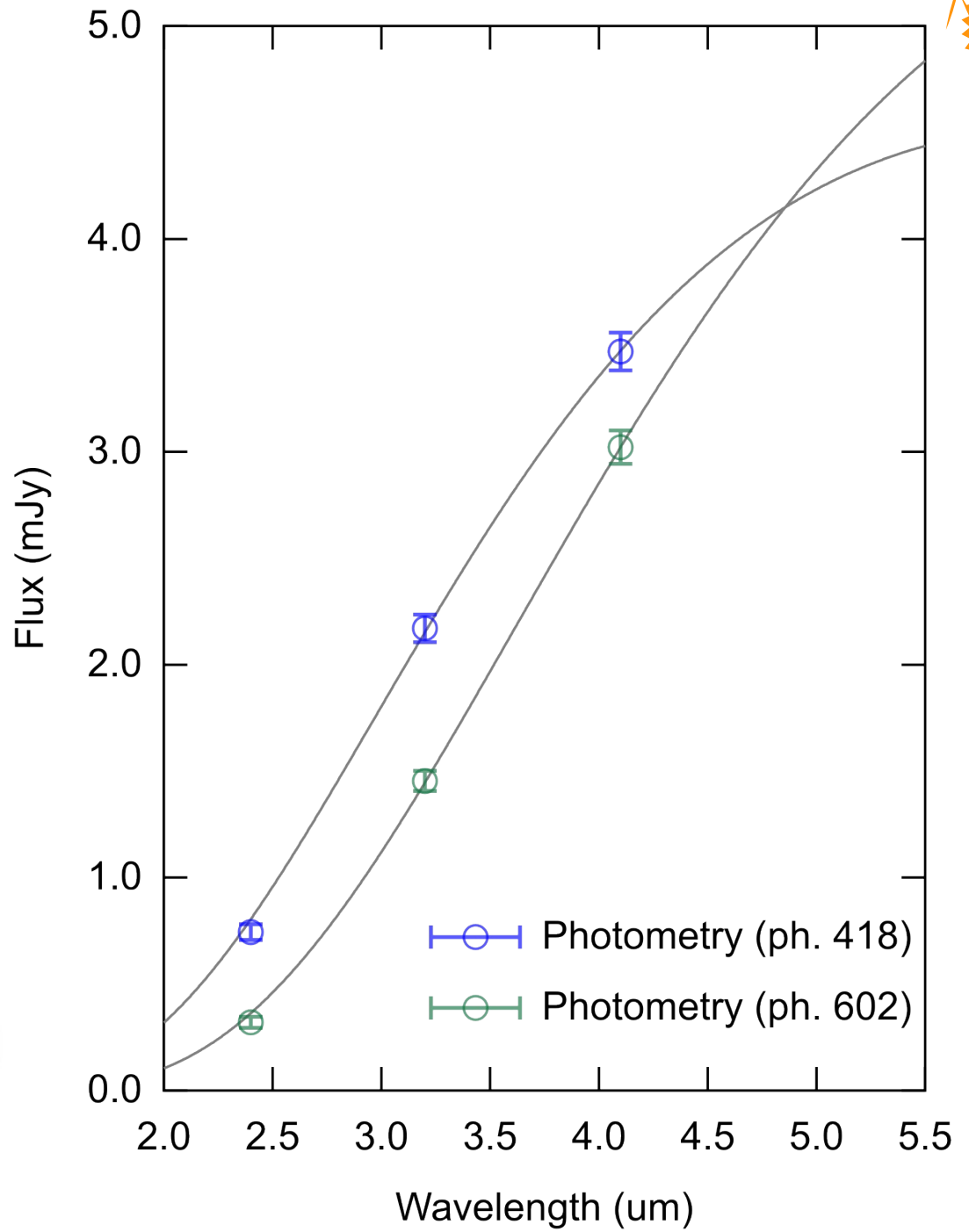
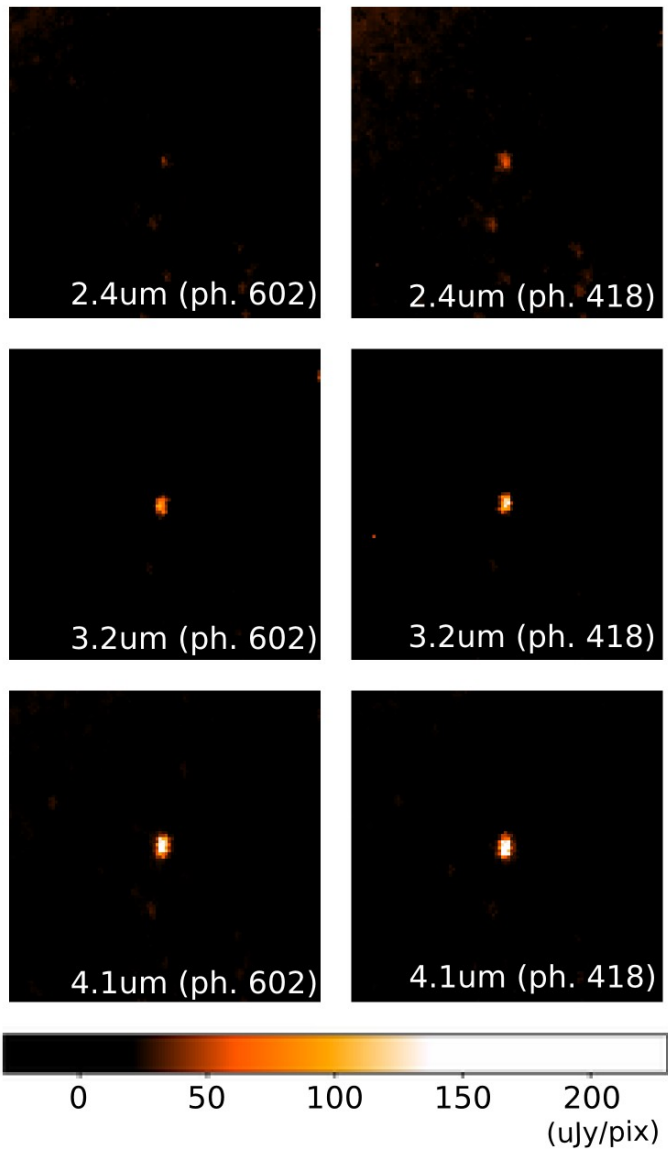

Optically thin

- dust temperature: $678 \pm 10\text{K} \rightarrow 573 \pm 12\text{K}$
- dust 量が一定であるという仮定の中では luminosity の変化を説明できない

Optically thick

- dust temperature: $813 \pm 10\text{K} \rightarrow 663 \pm 12\text{K}$
- expansion で emitting radius が広がったと考える
とつじつまが合う
- $2.4\mu\text{m}$ の optical depth が 5-10 程度

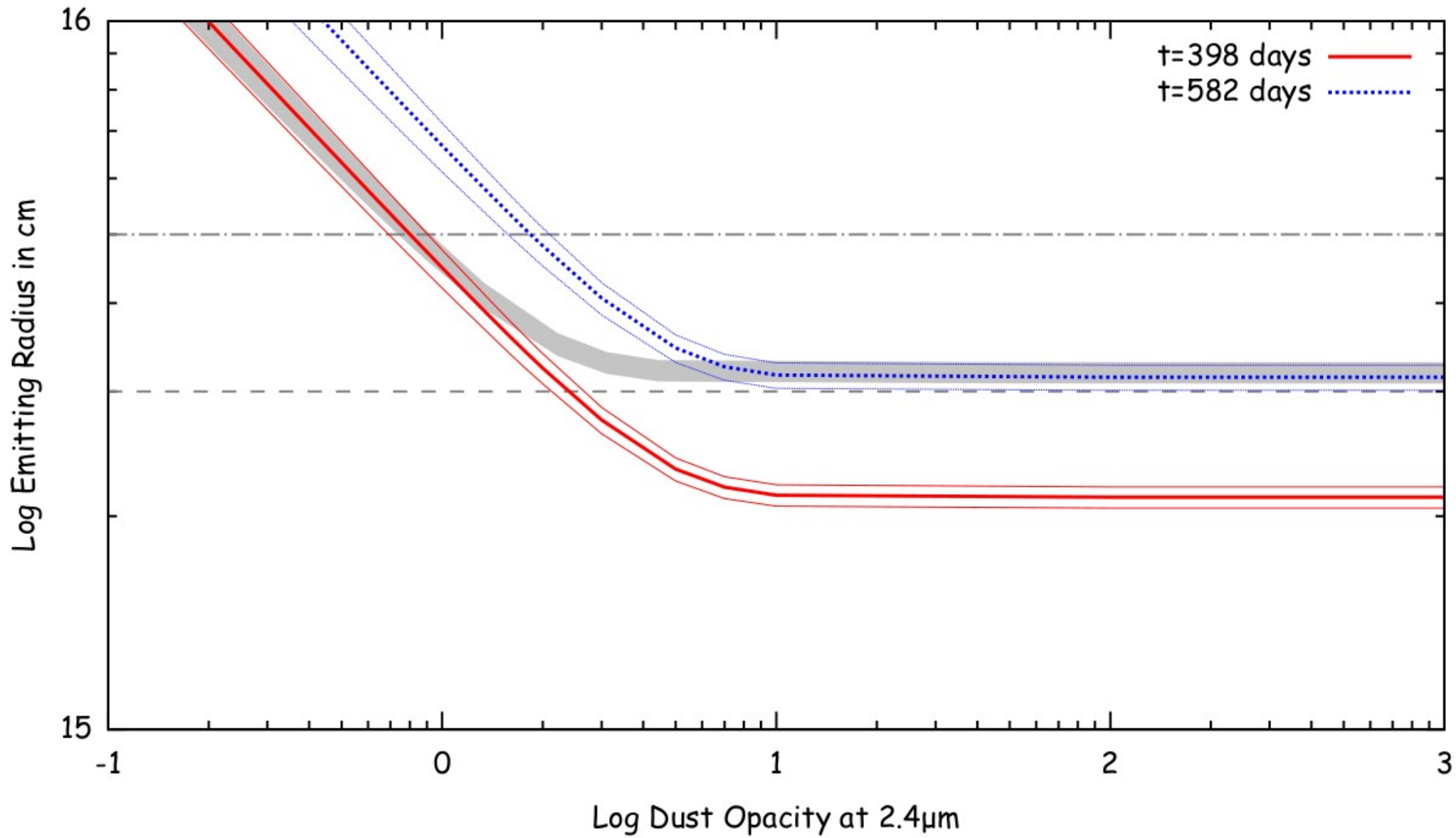

asymmetric dust cloud?

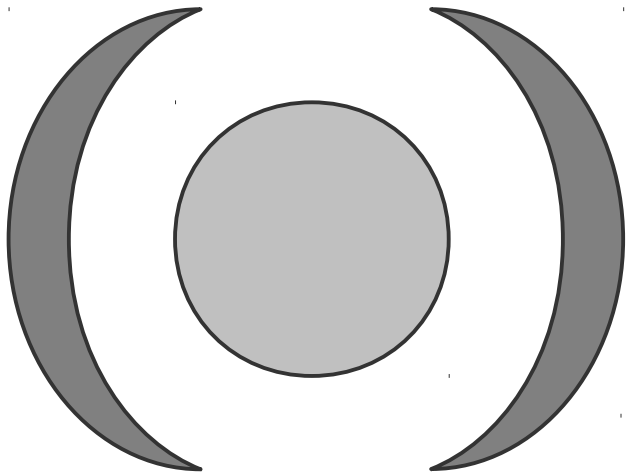

bipolar

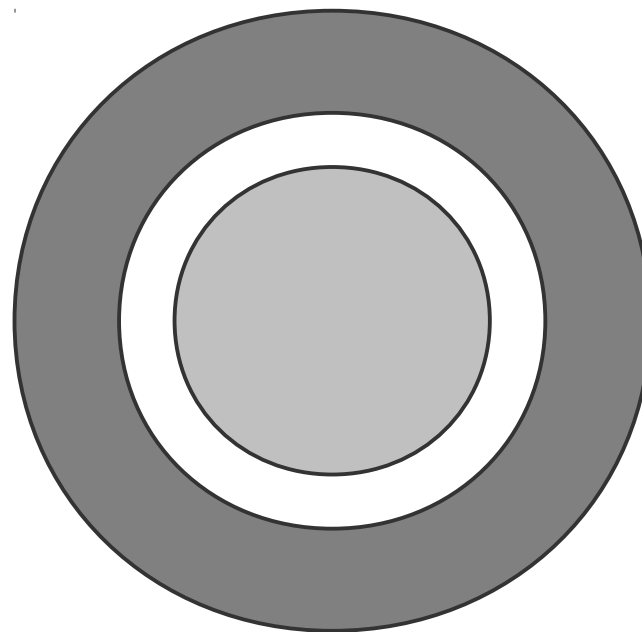

torus

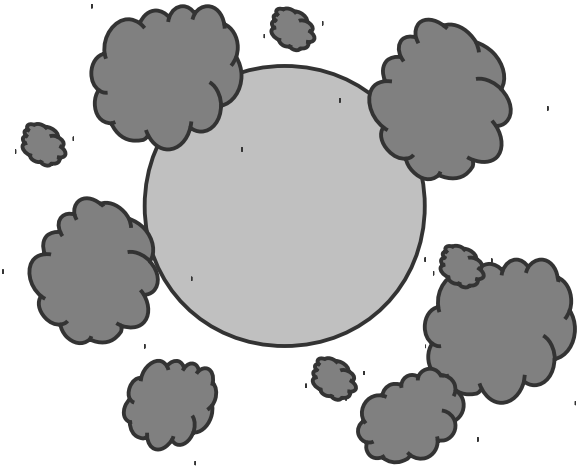

clumpy

SN 2008S

discovered
on Feb. 1, 2008
(~8 days after explosion)

distance:
~ 5.7 Mpc
luminosity:
~ -13 mag.

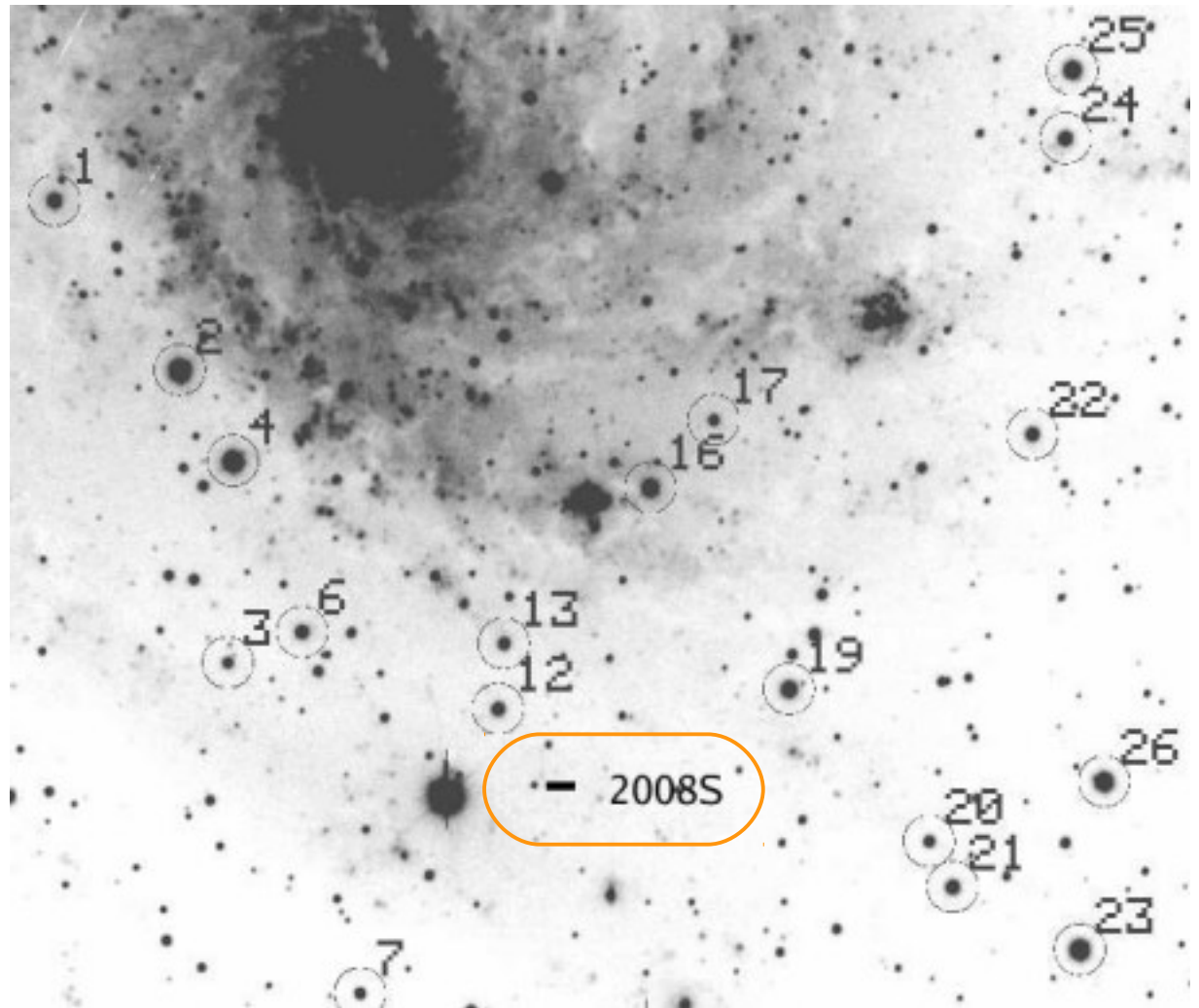

(Botticella+, 2008)

Jun. 15, 2008 (ph. 147)	N3(3.2um), N4(4.2um)
Jun. 15, 2009 (ph. 517)	N2(2.4um), N3(3.2um), N4(4.2um)
Dec. 21, 2009 (ph. 706)	N2(2.4um), N3(3.2um), N4(4.2um)

3 epoch の photometry が完了

取得したデータは全部で 4 epoch
1 epoch の photometry と 4 epoch 分の近赤外スペクトルが未処理

NIR light curve

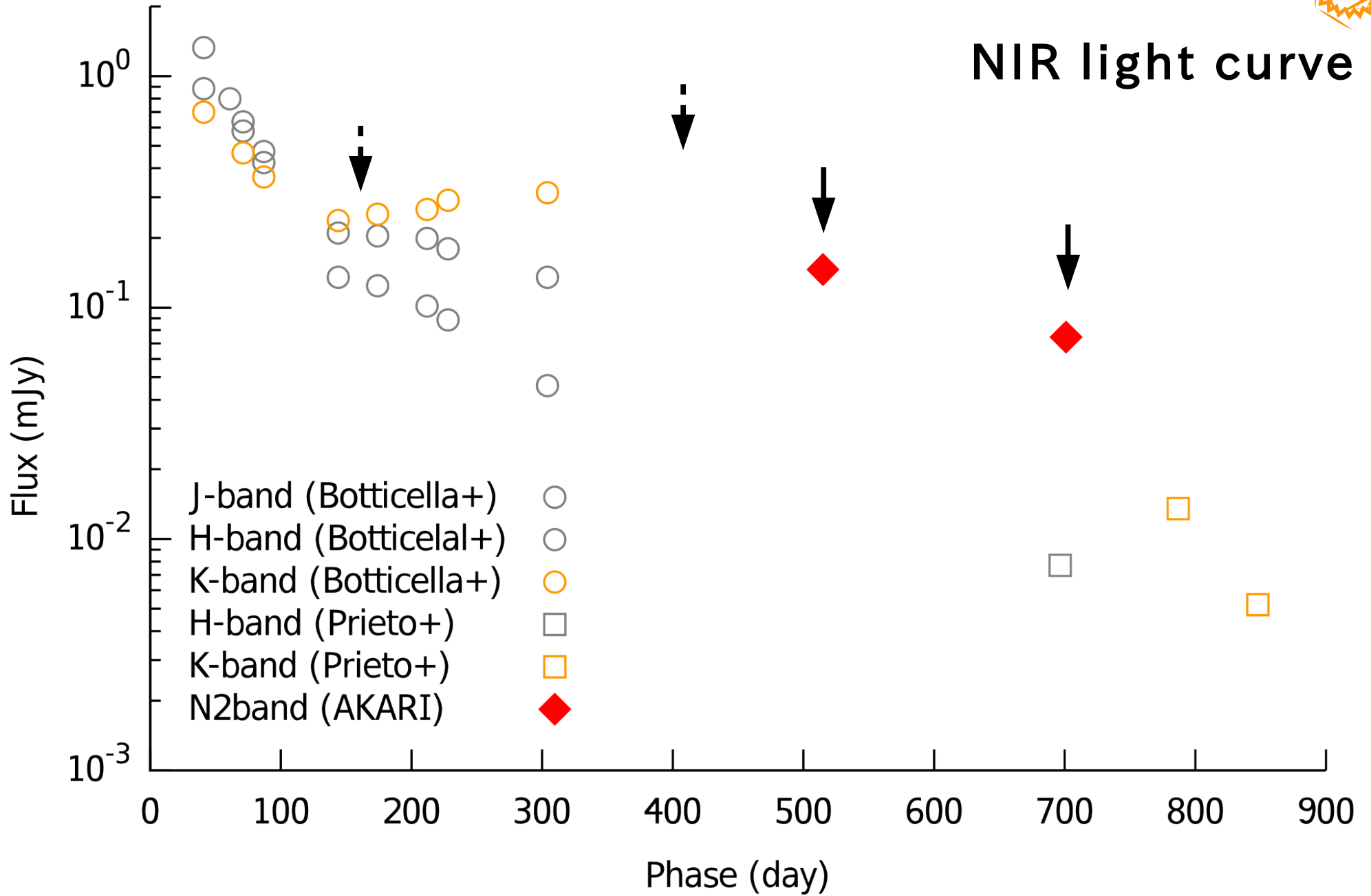

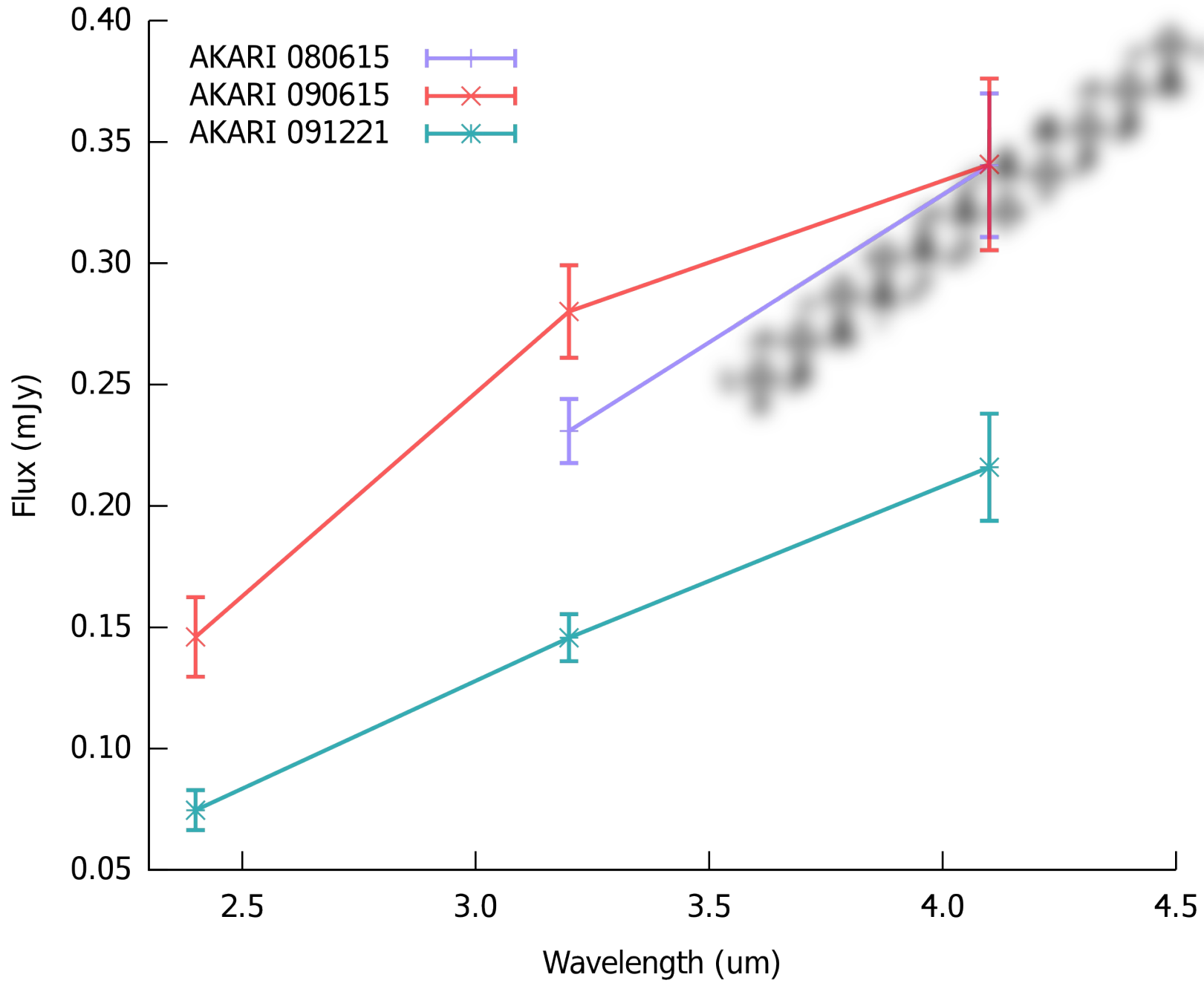

Future work on SN 2008S

- NIR excess の正体を明らかにする
 - MIR の light echo 成分を正確に見積る
 - NIR excess の時間変化を追う
- NGC300OT との類似点・相違点を調べる
 - optically thick dust cloud?
- 赤外線全体を積分した SED の挙動を調べる
 - エネルギー収支から OT の本質に迫る

ご清聴ありがとうございました!

